

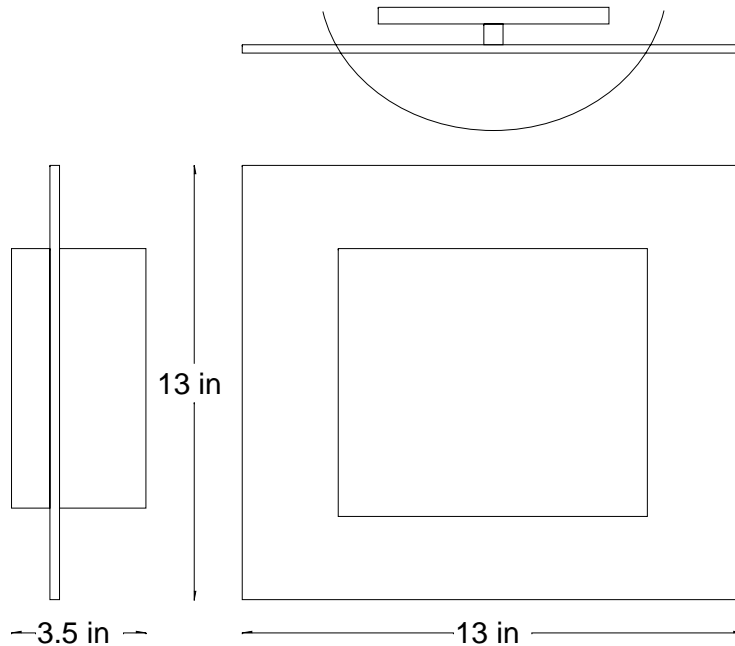

# LightPlane



## SPECIFICATIONS

### Construction

Backplate: .025" steel.  
Front: is .036" for nickel plated steel

### Finishes

Satin nickel with clear lacquer coating.

### Electrical

ETL listed dry location only.  
Specify 120 or 277v. Lamps by others.

### Lensing

UV stable extruded matte white acrylic

### Mounting

Mounts to octagon junction box or 4x4 junction box with round plaster adapter.

### Modifications

Contact local representatives or factory for size, lamping, lens or finish modifications.

## ORDERING LOGIC

Use matrix below to order complete fixture

Family	Model	Lamping	Voltage*	Finish			
LPW	13x13x4	1xF13 G24q1 2xF13 G24q1 1xF26 G24q3 2xF26 G24q3	120v 277v	SN Satin Nickel			

\*Required